

# BIBI26 / BIBI33 / BIBI46

BI-LEVELLING CRAWLER SCISSOR LIFTS

COMBUSTION / HYBRID / ELECTRIC



ALMACRAWLER 

**UP**  
EQUIP

# BIBI26 /

# BIBI33 / BIBI33PRIMO

# BIBI46 / BIBI46PRIMO

## MOVE LEVEL WORK

The innovative self-propelled tracked sciss with a patented self-levelling technology, th overcome s standard limits of traditional equipment.

With working heights from 26' to 46', load capacity of 550 to 880 lbs and the bi-levelling technology for up to 20° inclination, the BL Line was designed for safety and productivity on the jobsite!

Plate-forme à chenilles automotrice innovante dotée de technologie Auto-nivelant breveté, la ligne BL dépasse les limites conventionnelles de plateformes traditionnelles.

Avec des hauteurs de travail de 8 à 14 m, une capacité de charge de 250 à 400 kg et technologie bi-nivellement jusqu'à 20° d'inclinaison, la BL Line a été conçu pour assurer sécurité et productivité sur le chantier !

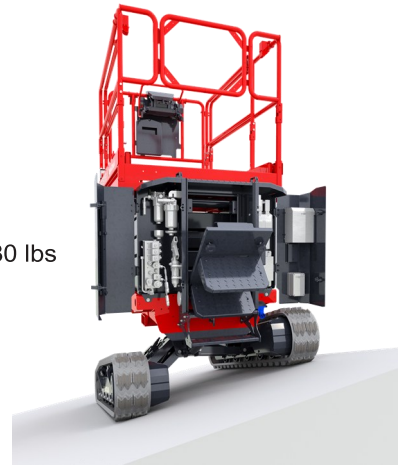

### BIBI46

46' working height  
Hauteur de travail  
30' Driving height  
Élévation en déplacement

### BIBI33

33' working height  
Hauteur de travail  
21' Driving height  
Élévation en déplacement

### BIBI26

26' working height  
Hauteur de travail  
20' Driving height  
Élévation en déplacement



## DYNAMIC LEVELLING



## PROACTIVE LEVELLING

20°/15° LONGITUDINAL  
15°/14° LATERAL

PATENTED TECH



# BIBI26 / BIBI33 / BIBI46

## BI-LEVELLING CRAWLER SCISSOR LIFTS

The world's only scissor lift capable of driving at height on a slope safely

- Exclusive Multi-axis/Self/Dynamic-Levelling to work and drive on slopes to 20°
- Super-rugged construction
- Multiple engine/battery combinations
- Fast driving speed up to 4.5 Km/h
- Fully proportional controls
- Extendable deck for increased work area
- Gradability up to 25°
- Indoor and outdoor operations
- Forklift pocket for easy handling and loading
- Many options like Operator anti -entrapment system, non-marking tracks



Technical data	BIBI26	BIBI33 BIBI33PRIMO	BIBI46 BIBI46PRIMO
Available configuration	<ul style="list-style-type: none"> <li>• Honda Gas</li> <li>• Kubota /Yanmar diesel</li> <li>• Hybrid Diesel + Lithium</li> </ul>	<ul style="list-style-type: none"> <li>• Kubota /Yanmar diesel</li> <li>• Hybrid Diesel with Lithium 100Ah 48V</li> <li>• Lithium 210Ah 48V with Full electric direct drive -</li> </ul>	<ul style="list-style-type: none"> <li>• Yanmar diesel</li> <li>• Lithium 420Ah 48V with Full electric direct drive -</li> </ul>
Basket capacity	551 lbs / 250 kg (2 op.)	661 lbs / 300 kg (2 op.)	881 lbs / 400 kg (2 op.)
Basket size	4'-11" x 3'11" (1.50 x 1.20 m)	5'-11" x 4'3" (1.80 x 1.30 m)	5'-11" x 4'3" (1.80 x 1.30 m)
Max working height	25'-11" (7.9 m)	32'-10" (10.0 m)	46'-0" (14.4 m)
Max height basket floor	19'-4" (5.9 m)	26'-10" (8.0 m)	40'-0" (12.13 m)
Moving height	19'-8" (6.0 m)	21'-4" (6.5 m)	30'-4" (9.23 m)
Accelerator	Automatic	Automatic	Automatic
Undercarriage	Bi-Levelling	Bi-Levelling	Bi-Levelling
Basket levelling	Automatic	Automatic	Automatic
Longitudinal levelling Front	+/- 16°	+/- 15°	+/- 15°
Longitudinal levelling Rear	+/- 20°	+/- 20°	+/- 15°
Lateral levelling	+/- 15°	+/- 14°	+/- 14°
Electric pump (option)	110Vac	110Vac	110Vac
Direction-Control System	Yes	Yes	Yes
Easy-Drive System	Yes	Yes	Yes
Max speed	max 1.37 Mph / 2.20 km/h	max 1.50Mph / 2.40 km/h PRIMO max 2.80Mph / 4.50 km/h	max 1.55Mph / 2.50 km/h PRIMO max 2.50Mph / 4.00 km/h
Ground emergency	Yes	Yes	Yes
Control of inclination	Automatic	Automatic	Automatic
Gradeability	25°	25°	25°
Side slope	21°	21°	21°
Length	6'-4" / 1.94 m	7'-7" / 2.28 m	9'-11" / 3.02 m
Width	51.2" / 59.1" 1.30 / 1.50 m	47.2" / 64.5" 1.46 / 1.64 m	66" / 80" 1.69 / 2.03 m
Min height with narrow tracks (folded railings)	90" (78") / 2.28 (1,98) m	95.5" ( 82.28") / 2.42 (2,09) m	113" ( 88") / 2.86 (2,54) m
Min height with wide tracks (folded arailings)	78" ( 66.15") / 1.98 (1,68) m	82.3" ( 68.89") / 2.09 (1,75) m	98" ( 73") / 2.48 (2.16) m
Weight (variable upon motorisation)	5400 to 5555 lbs	6305 to 6525 lbs	11 464 to 11574 lbs

## PRIMO

### THE EVOLUTION OF A REVOLUTION

- Full electric
- Electric drive
- Removable Power Pack
- Easy maintenance
- Anti-Entrapment System
- Automatic Tensioner System

- Entièrement électrique
- Traction électrique
- Batterie amovible
- Entretien facile
- Système anti-piégeage
- Système de tension automatique



### REMOVABLE POWER PACK

Batteries interchangeables



### FORKLIFT POCKETS

Pochette pour fourches

### DYNAMIC LEVELLING

Autonomous self-levelling function when the basket is fully lowered.

No operator intervention necessary.

### NIVELLEMENT DYNAMIQUE

Fonction de nivellement automatique dans des conditions du transport.

Aucune intervention de l'opérateur n'est nécessaire.

### PROACTIVE LEVELLING

Self-levelling function when the basket is at height up to 30' working height.

### NIVEAU PROACTIF

Fonction de nivellement à des hauteurs allant jusqu'à 9.3 m.

### ANTI-ENTRAPMENT SYSTEM

Système anti-piégeage



### EASY MAINTENANCE

Entretien facile



# BIBI33PRIMO

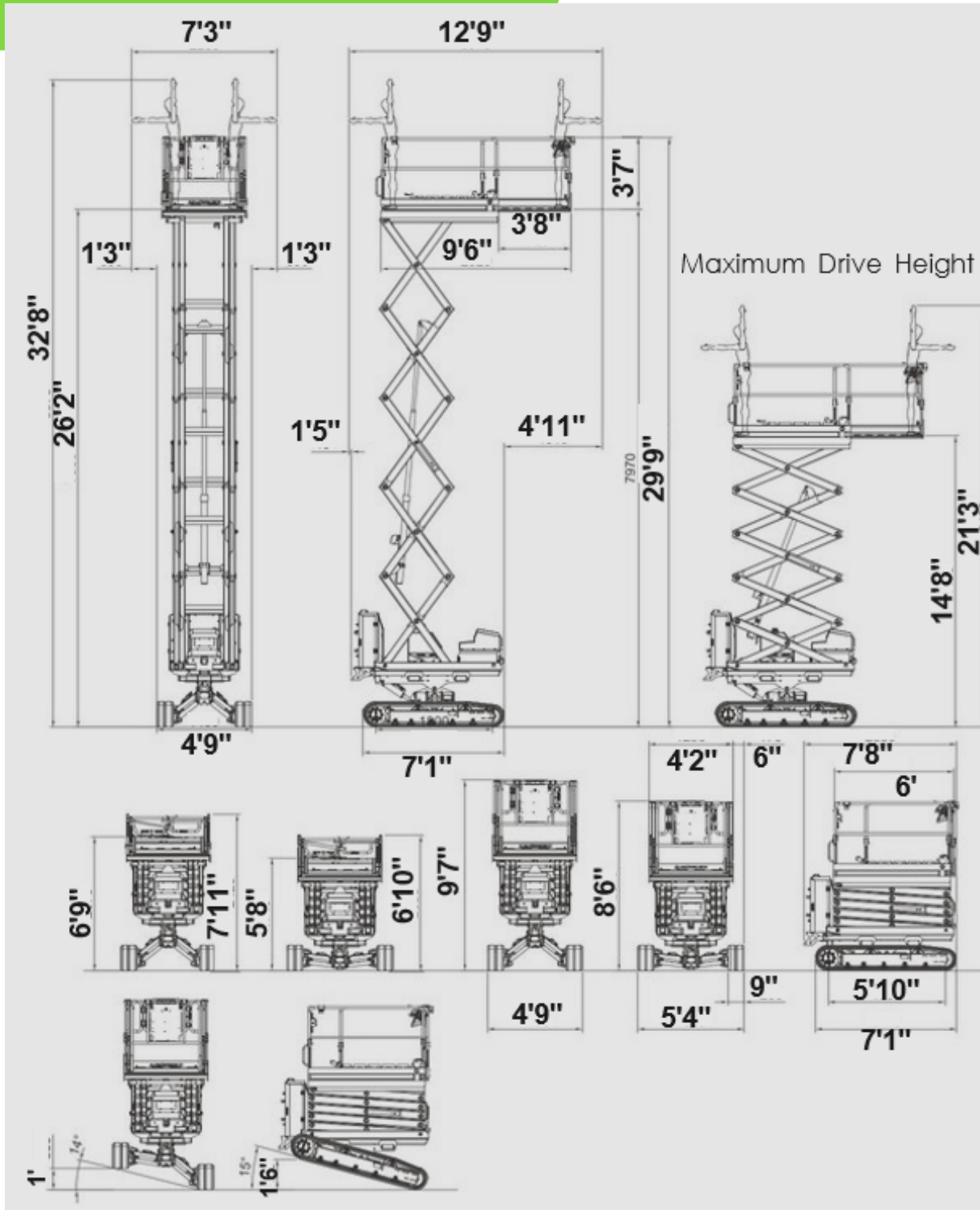

# BIBI46

